



Rewarding Learning

ADVANCED  
General Certificate of Education  
2023

Centre Number

--	--	--	--	--

Candidate Number

--	--	--	--

---

## Life and Health Sciences

Assessment Unit A2 5

*assessing*

Genetics, Stem Cell Research  
and Cloning

**MV24**

**[AZ051]**

**MONDAY 26 JUNE, AFTERNOON**

---

### **Time**

1 hour 45 minutes, plus your additional time allowance.

### **Instructions to Candidates**

Write your Centre Number and Candidate Number in the spaces provided at the top of this page.

**You must answer the questions in the spaces provided.**

**Do not write on blank pages.**

Complete in black ink only.

Answer **all nine** questions.

Write your answers in the spaces provided in this question paper.

---

## Information for Candidates

The total mark for this paper is **100**.

Figures in brackets printed at the end of each question indicate the marks awarded to each question or part question.

You may use an electronic calculator.

Quality of written communication will be assessed in question **6(a)**.

**Blank Page**

**(Questions start overleaf)**

- 1 The diagram below shows the process of DNA replication in cells.

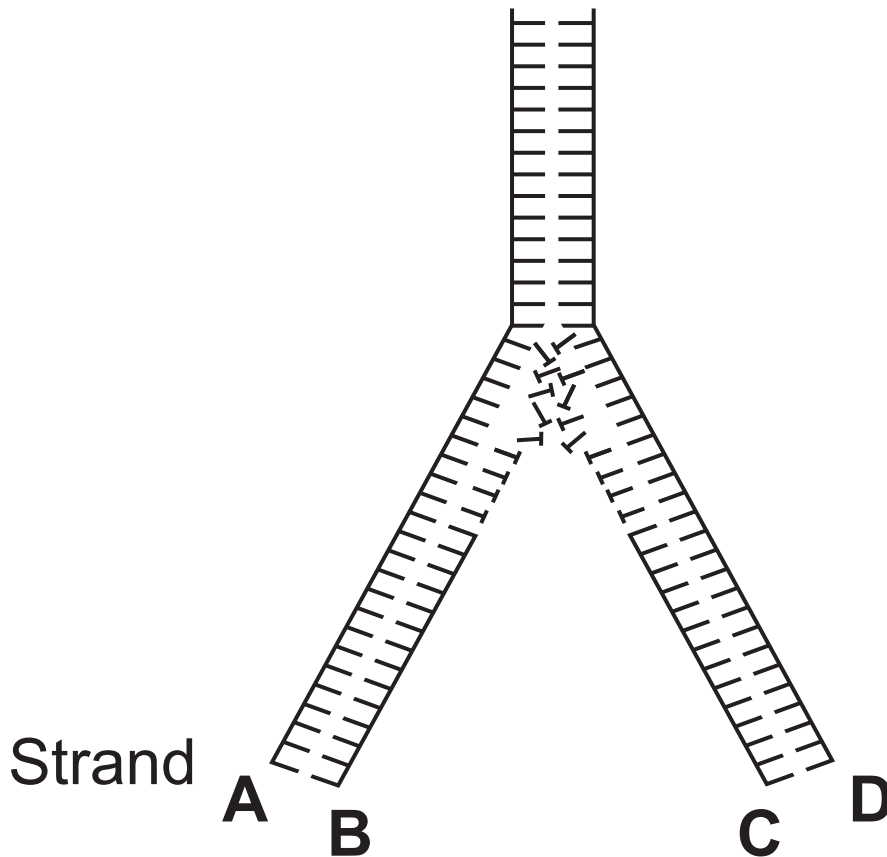

Complete the sentences below about DNA replication by writing the most appropriate word(s) or letters in the blank spaces.

[4 marks]

The diagram shows the parental DNA being separated (unwound) as a result of the enzyme \_\_\_\_\_ breaking the \_\_\_\_\_ bonds which link complementary bases together.

Two strands then act as templates to form new DNA.

The template strands in the diagram are labelled with the letters \_\_\_\_\_ and \_\_\_\_\_ .

The diagram shows the \_\_\_\_\_ theory of DNA replication.

2 The diagram below summarises the properties of stem cells.

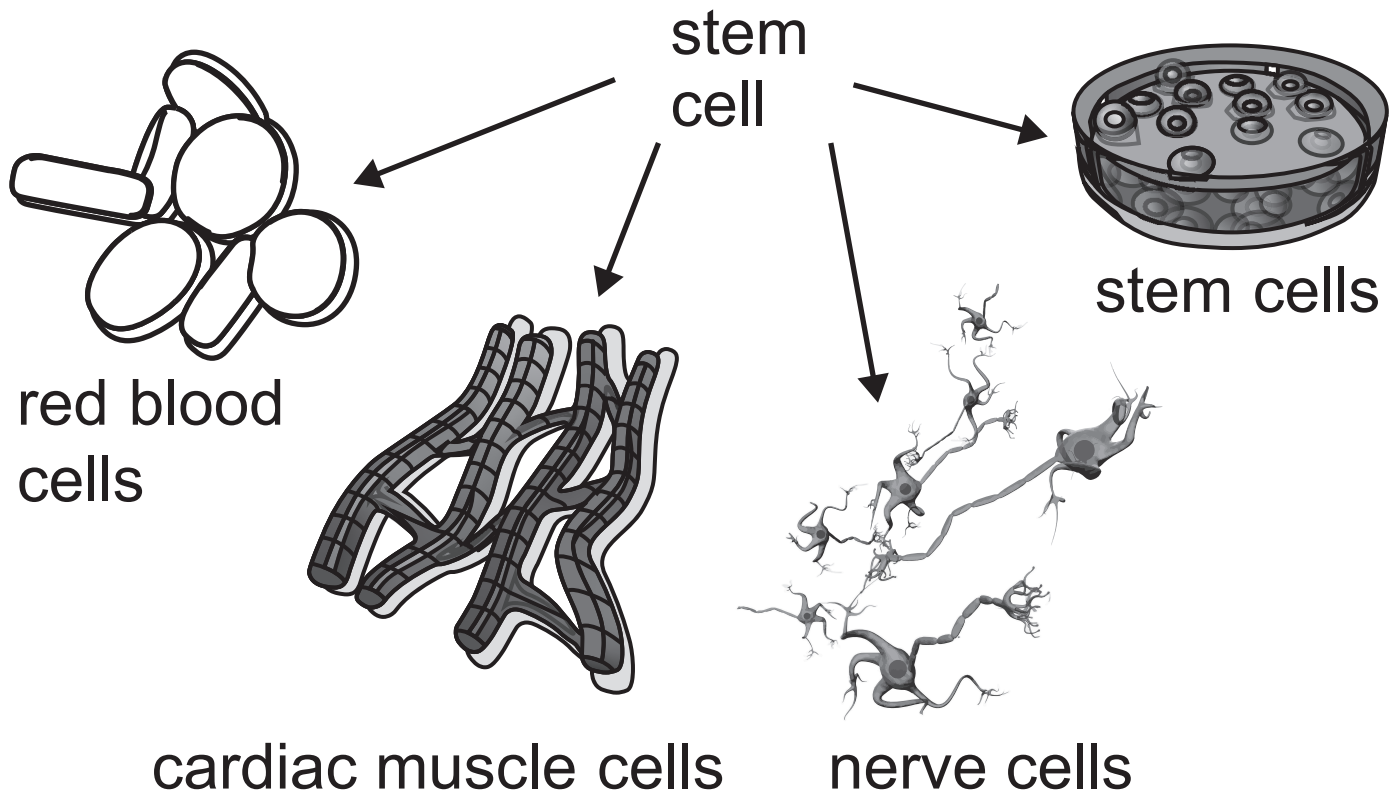

(a) Embryonic and adult stem cells are the two main types of stem cell.

(i) Give **one** similarity between embryonic and adult stem cells.  
[1 mark]

---

---

**(ii)** Give **one** difference between embryonic and adult stem cells.  
[1 mark]

---

---

**(iii)** Name **one** place in the body in which adult stem cells are found. [1 mark]

---

**(b)** Stem cells are being increasingly used in medicine.

Explain why there are few ethical issues about the use of adult stem cells in this role. [1 mark]

---

---

**3** Making cheeses such as Cheddar traditionally involves adding protease enzymes to milk.

One of these enzymes is rennet.

It is produced by the stomach lining of young calves.

**(a)** Give the function of rennet in making cheese. [1 mark]

---

---

**(b)** One protease enzyme, called chymosin, can be used instead of rennet in cheese making.

This enzyme can be produced by genetic engineering (GE) where the gene for chymosin is inserted into bacteria such as *E. coli*.

These modified bacteria then produce large quantities of GE chymosin at low cost.

**Blank Page**

**(Questions continue overleaf)**

The graph below shows the quantities of cheese made using rennet and GE chymosin over a 25-year period in a large cheese-making company.

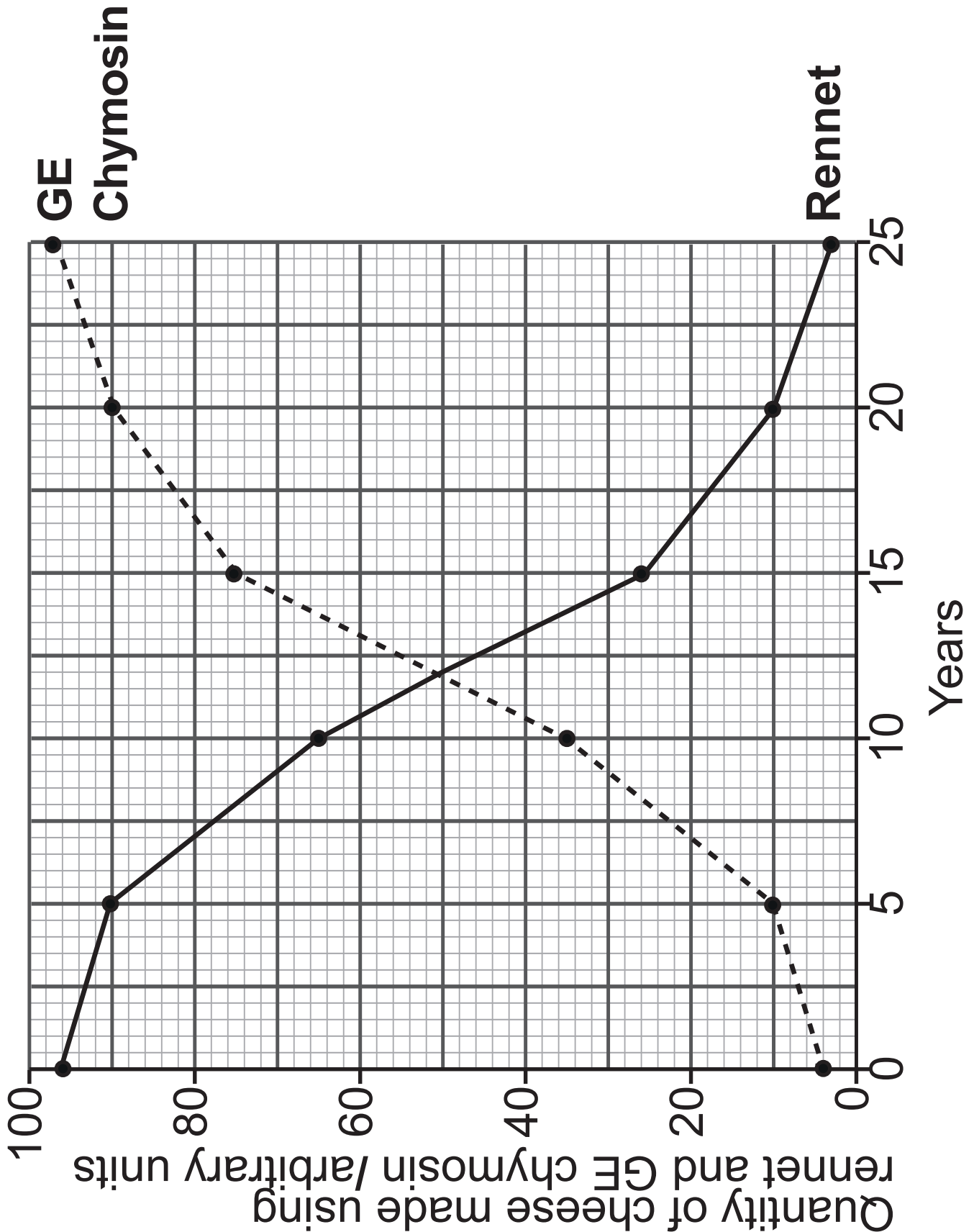

(i) After how many years was the quantity of cheese made using rennet and GE chymosin the same?

[1 mark]

\_\_\_\_\_ years

(ii) Calculate the percentage decrease in quantity of rennet used over the 25 years. [3 marks]

**You are advised to show your working.**

\_\_\_\_\_ %

**(iii)** Using the information provided and your knowledge, give three reasons for this decrease. [3 marks]

1. \_\_\_\_\_

\_\_\_\_\_

2. \_\_\_\_\_

\_\_\_\_\_

3. \_\_\_\_\_

\_\_\_\_\_

**(iv)** Suggest why some manufacturers still use rennet to produce their cheese. [1 mark]

\_\_\_\_\_

**(c)** During genetic engineering, DNA probes are often used to identify the position of a gene.

The diagram opposite shows part of a DNA probe which is labelled with a fluorescent substance.

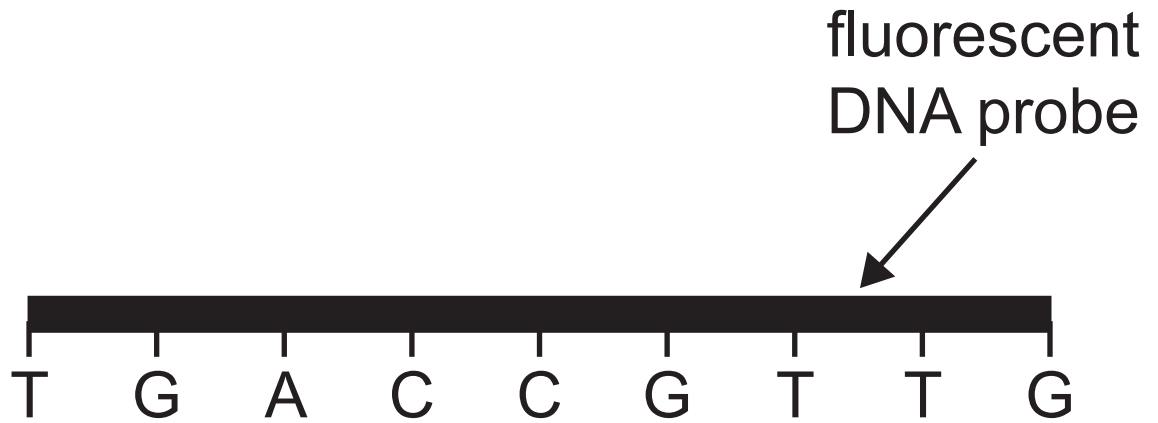

(i) Using the diagram and your knowledge, explain how a DNA probe can be used to identify the location of a gene of interest. [3 marks]

---

---

---

---

---

---

---

---

---

---

(ii) DNA probes can also be used to screen medical patients. Give **one** example of DNA probes in this context. [1 mark]

---

---

- 4 The diagram below shows the structure of a DNA nucleotide.

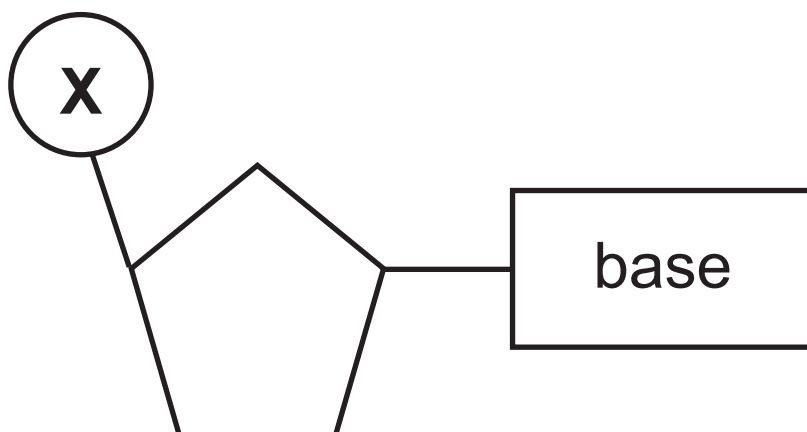

- (a) Name the component labelled **X**.  
[1 mark]
-

**(b)** By knowing the percentage of any one of the four bases in a section of DNA, it is possible to work out the percentages of the other bases present.

**(i)** Complete the table below by calculating the percentage of the remaining bases. [3 marks]

<b>Name of base</b>	<b>Percentage of base in a section of DNA</b>
Adenine	28
Guanine	
Cytosine	
Thymine	

The relationship between the relative proportions of the different bases is referred to as base equivalence.

**(ii)** Name the scientist who is credited with working out the principle of base equivalence. [1 mark]

(c) The diagram below shows a sequence of bases along the coding strand of DNA. This determines the order in which amino acids are built up in a polypeptide.

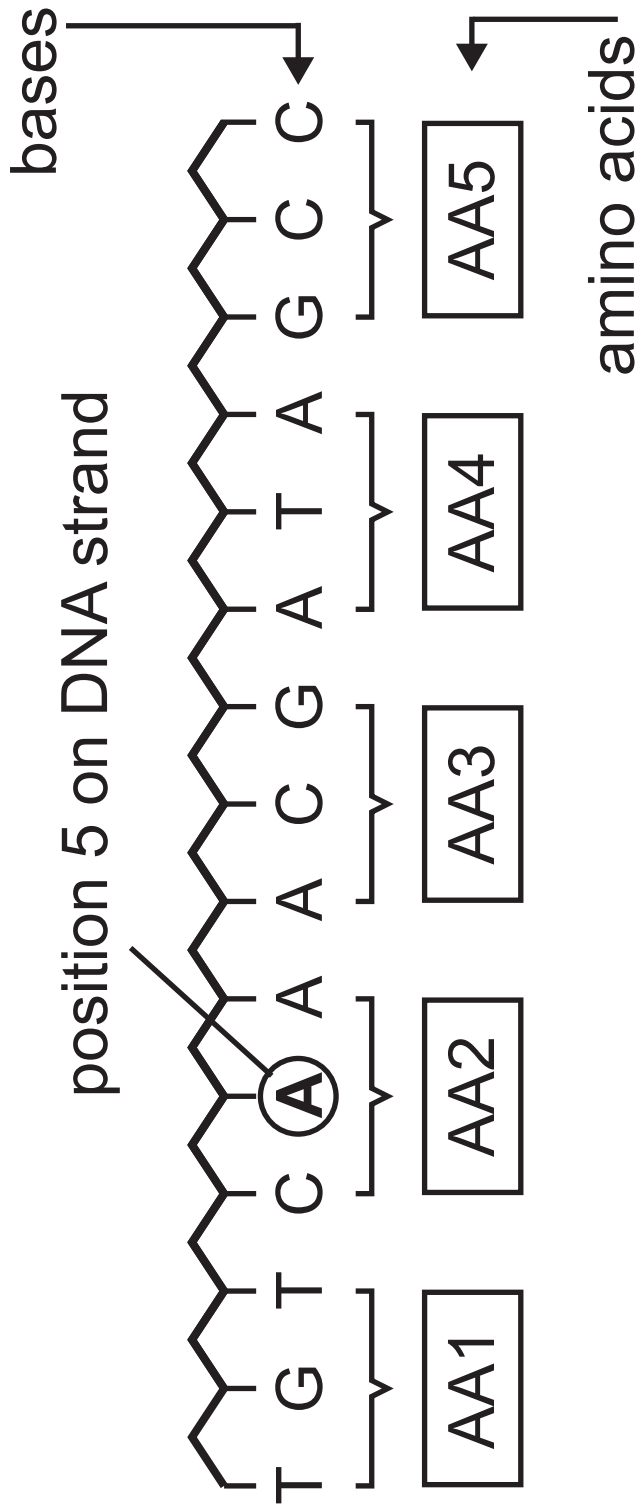

Occasionally, DNA can become damaged by one or more nucleotides being added or deleted from a section of DNA.

- (i) State the name given to a change in a DNA sequence. [1 mark]
-

The diagram opposite shows the same DNA sequence. The base at position 5 becomes deleted.

**(ii)** Describe the effect deleting base A at position 5 will have on the polypeptide produced. [4 marks]

---

---

---

---

---

---

---

---

---

---

---

---

base A **deleted** at position 5  
on the DNA sequence

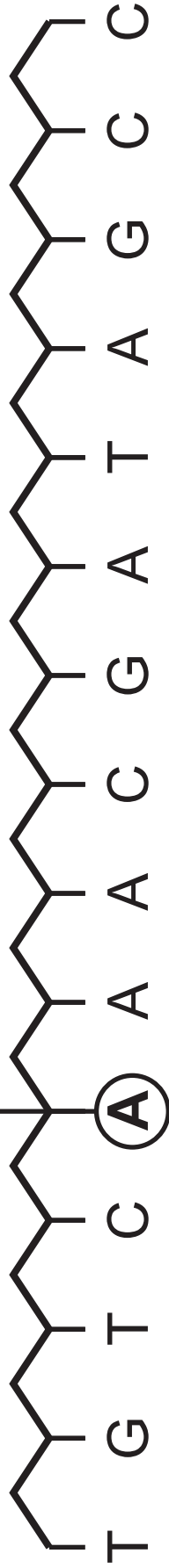

The original section of DNA could have changed in another way.

The **A** at position 5 on the DNA sequence could have been replaced with a different base rather than being deleted.

(iii) Describe how this would affect the polypeptide produced. [2 marks]

---

---

---

---

---

**Blank Page**

**(Questions continue overleaf)**

**5** Insulin is a hormone which lowers blood glucose levels.

**(a)** State **one** way in which insulin lowers blood glucose levels. [1 mark]

---

---

Diabetes mellitus is a condition in which affected individuals do not produce enough (or any) insulin, or the insulin produced does not work effectively.

The graph opposite shows the blood glucose levels of two individuals, one with diabetes and one who does not have diabetes, over a period of several hours.

Both had a similar meal at time 0.5 hours.

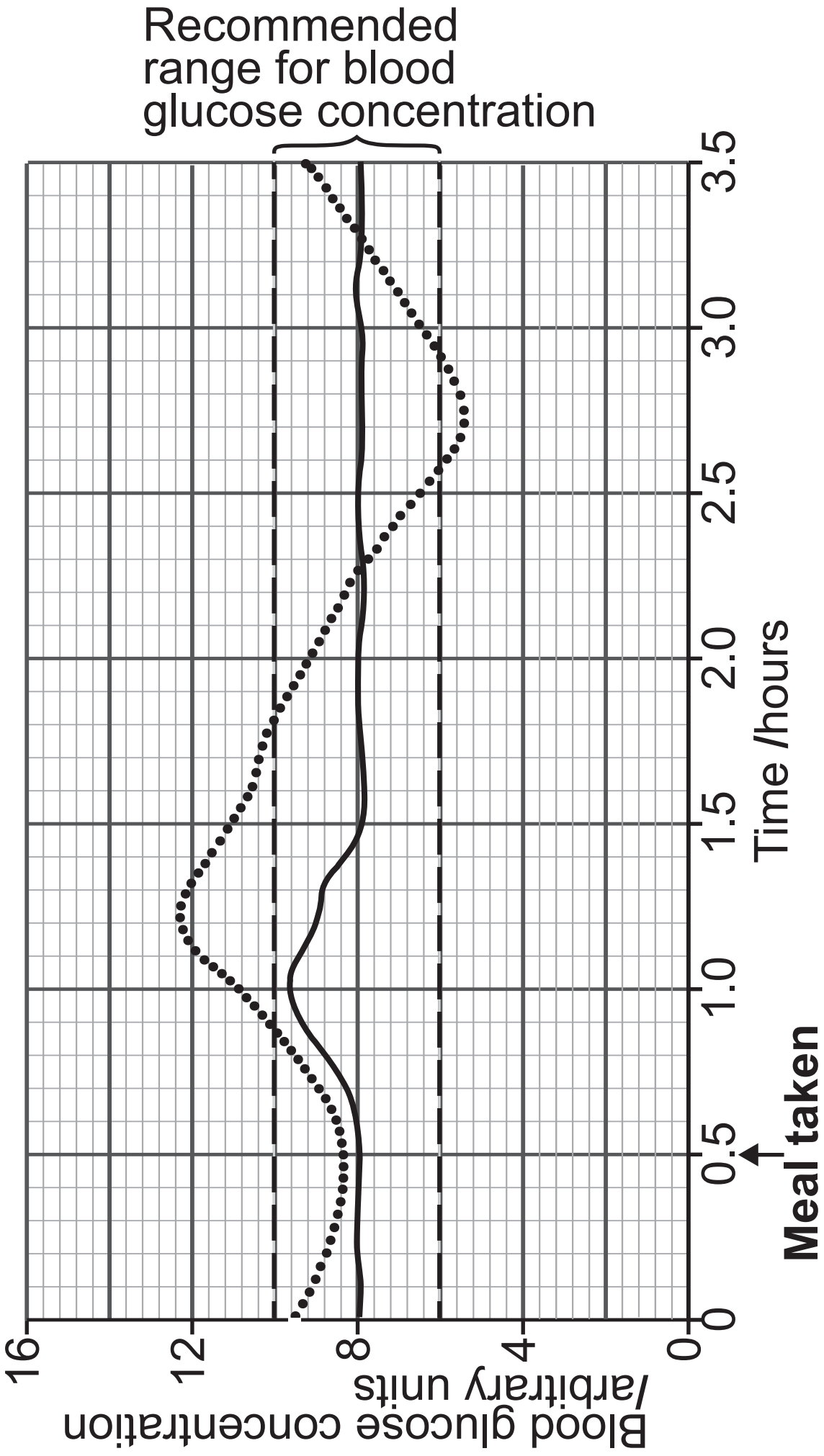
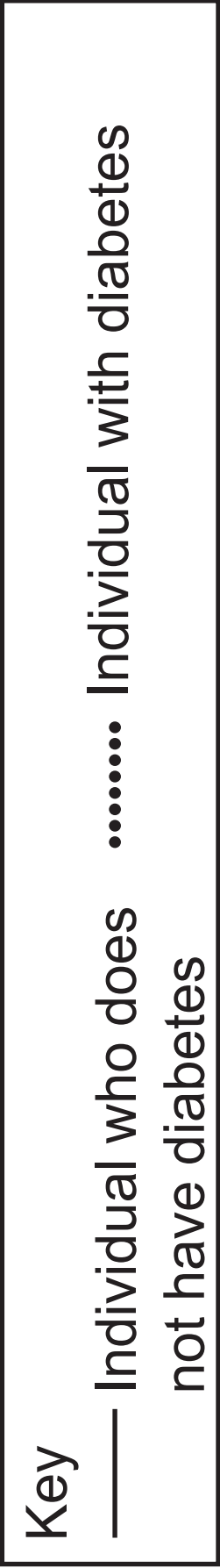



**(c)** As part of the process of producing genetically engineered insulin, it was necessary to isolate the human insulin gene.

**(i)** State the name given to the position of a gene on a section of DNA.  
[1 mark]

---

Once the location of the gene was identified, special enzymes were used to cut the DNA on either side of the gene.

These enzymes recognise a series of bases in DNA (a recognition sequence).

In the example shown below, the enzyme recognises the sequence GAATTC and then cuts the DNA between adjacent A and G bases as shown.

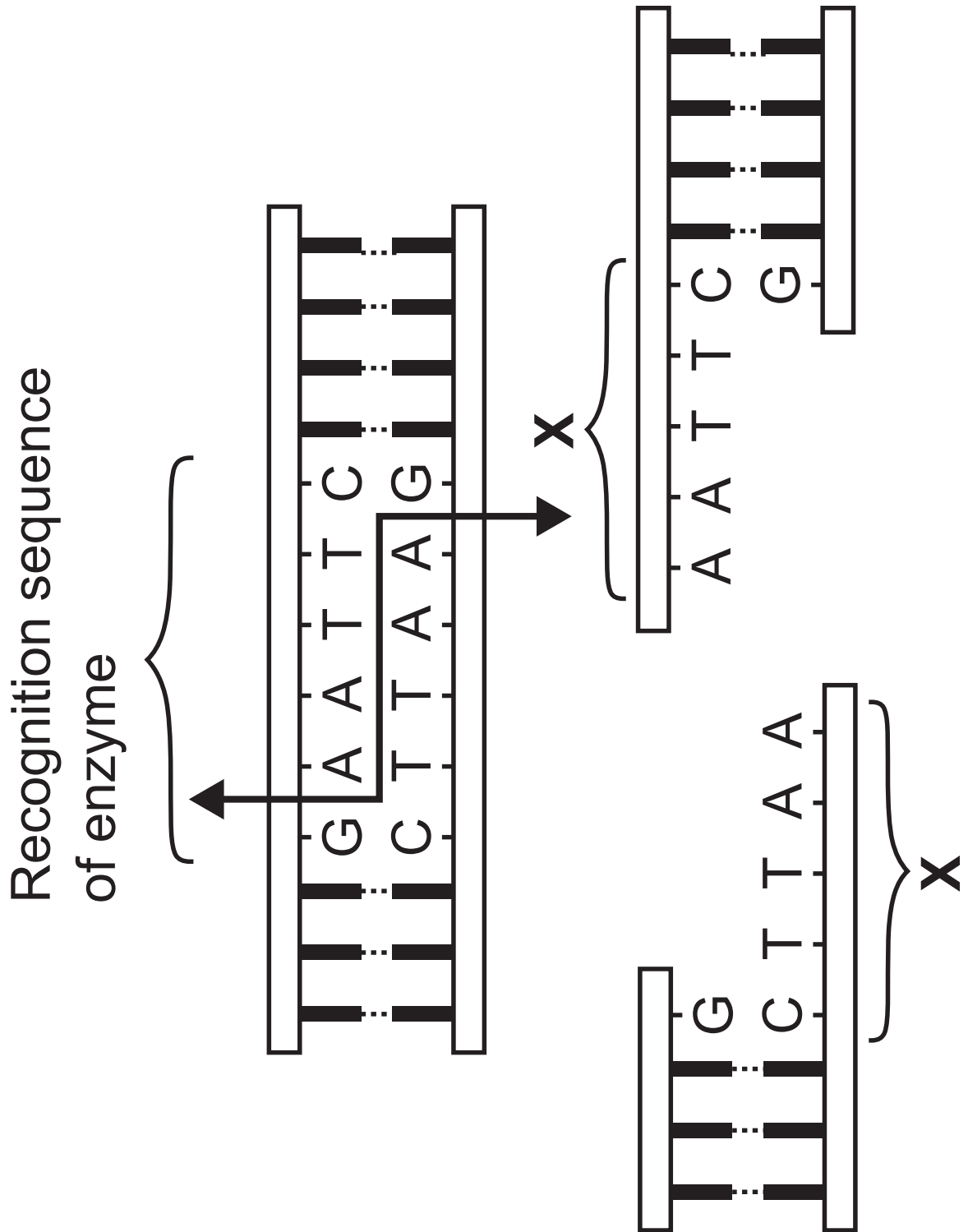

**(ii)** Name the type of enzymes involved in cutting the DNA. [1 mark]

---

**(iii)** Name the sections of DNA labelled **X**. [1 mark]

---

Once the insulin gene has been isolated, it is important that it is then inserted within the bacterial DNA in a certain place so that it will lead to the bacteria producing the insulin as required.

**(iv)** Explain how the sections of DNA labelled **X** can help with this process. [2 marks]

---

---

---

---

**(d)** People with haemophilia are unable to produce all the chemicals required to clot their blood.

They are unable to produce factor VIII.

**(i)** State why individuals with haemophilia are unable to produce factor VIII. [1 mark]

---

Factor VIII can now be produced by genetic engineering and used to treat people with haemophilia.

**(ii)** State how people with haemophilia were treated before genetically engineered factor VIII became available. [1 mark]

---

---

**(iii)** Give **one** health advantage of using genetically engineered factor VIII rather than the earlier treatment method. [1 mark]

---

---

**6** Genetic fingerprinting is a technique increasingly used in forensic science, plant and animal breeding and medical diagnosis.

**(a)** Describe the process of genetic fingerprinting.

Your answer should include:

- the role of the polymerase chain reaction (PCR) and why it may be necessary;
- the parts of the genome involved and their significance; and
- the laboratory techniques involved in producing the fingerprint.

[8 marks]

**Quality of written communication will be assessed in this question.**

---

---

---

---

---

---

---



**(b)** Give **one** reason for the use of genetic fingerprinting in medical diagnosis and in animal breeding. [2 marks]

Medical diagnosis

---

---

---

Animal breeding

---

---

---

**Blank Page**

**(Questions continue overleaf)**

7 Meiosis is a type of cell division often described as 'reduction' division.

(a) Using your knowledge of meiosis, suggest why the term 'reduction' is used [1 mark]

---

---

(b) The diagram below shows a pair of homologous chromosomes during an early stage (prophase 1) of meiosis.

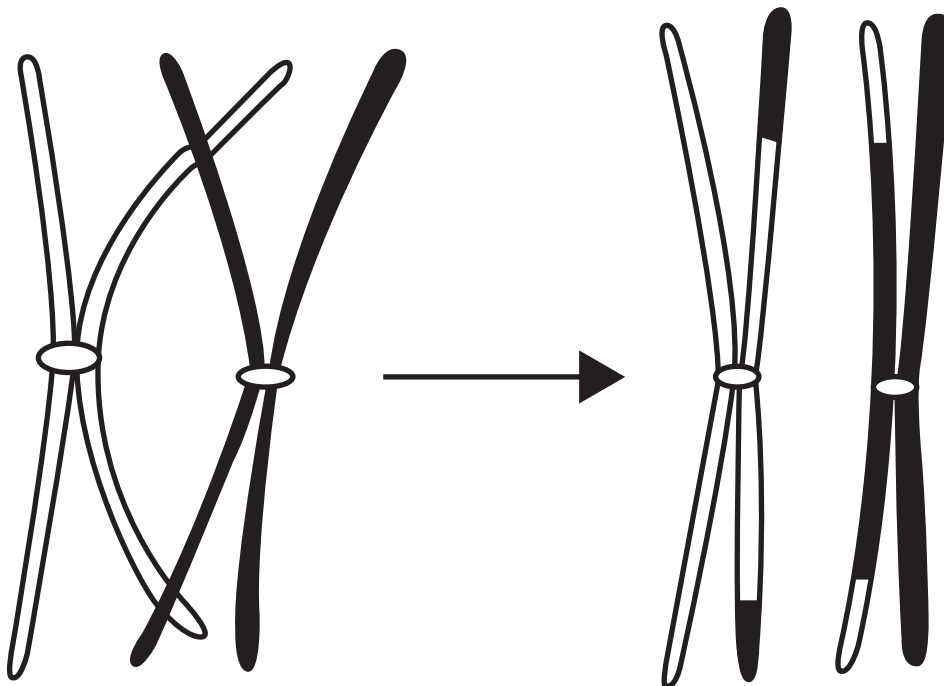

**(i)** Name the process represented by the diagram. [1 mark]

---

**(ii)** How many chiasmata are shown? [1 mark]

---

**(iii)** Using the diagram and your knowledge, explain the significance of this process. [3 marks]

---

---

---

---

---

---

---

**(c)** Read the passage below and answer the questions which follow.

Following the stage of meiosis in **(b)**, each pair of homologous chromosomes line up at the equator in a random arrangement.

This diagram shows two pairs of homologous chromosomes.

When they have lined up at the equator, each pair of homologous chromosomes gets pulled apart to the two different poles of the cell.

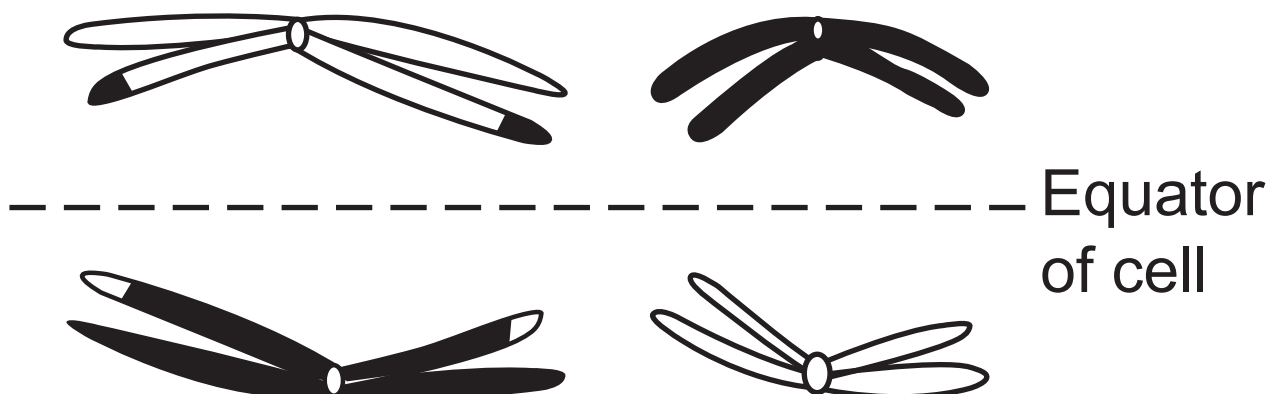

**(i)** Name the process by which chromosomes line up at the equator.  
[1 mark]

(ii) Explain how this process contributes to variation. [2 marks]

---

---

---

---

---

(d) Down's Syndrome is a condition where an extra chromosome is present in the body cells of the individual.

(i) Give the number of chromosomes in a human **gamete** that has an extra chromosome. [1 mark]

---

(ii) Using your knowledge of meiosis, suggest how a gamete could be produced which has an extra chromosome. [1 mark]

---

---

---

(e) The relationship between the number of babies born with Down's Syndrome in Northern Ireland and the maternal age when the baby is born is shown in the table below.

<b>Maternal age</b>	<b>Number of children born with Down's Syndrome (rate per 1000 total births)</b>
19 and under	0.67
20 – 24	0.85
25 – 29	0.76
30 – 34	1.28
35 – 39	4.50
40 – 44	15.33
45 and over	21.93

**(i)** Summarise the data shown in the table. [3 marks]

---

---

---

---

---

---

---

---

**(ii)** Suggest a possible explanation for the results shown. [1 mark]

---

---

---

**8 (a)** The diagram opposite shows the process of 'in-vitro' fertilisation that can be used during fertility treatment.

If fertilisation takes place, the resulting embryo is implanted into the woman's uterus.

Gene therapy is now making it possible to edit the DNA in the cells of early embryos before they are placed into the woman's uterus.

**(i)** Name this type of gene therapy.  
[1 mark]

---

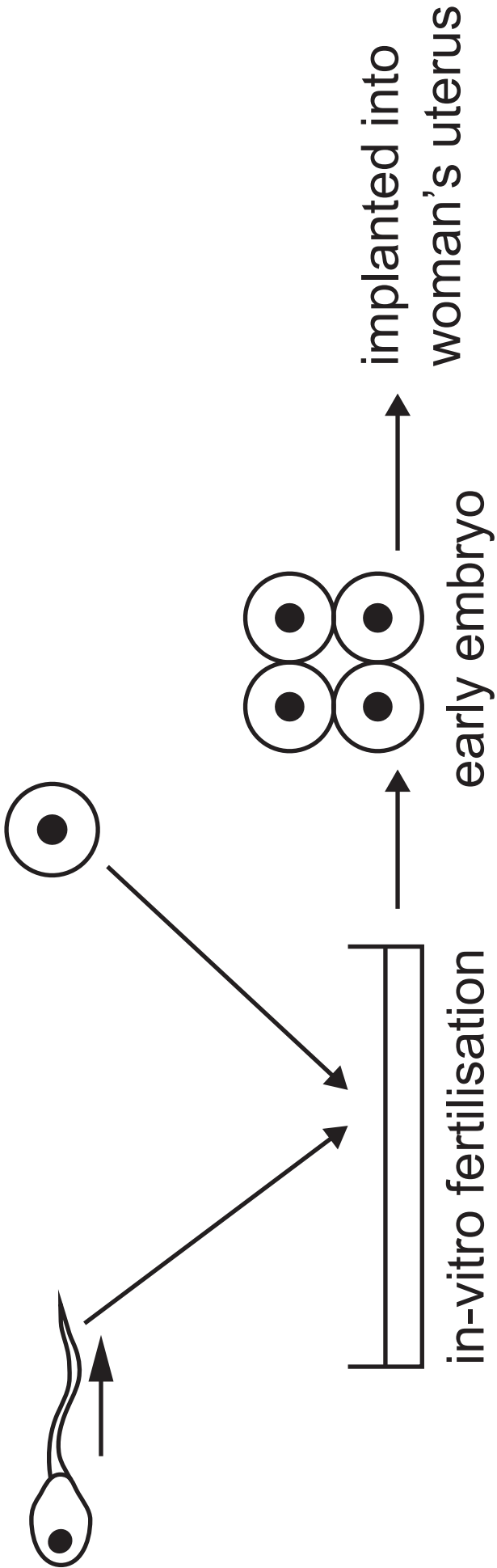

**(ii)** Explain fully a possible health benefit in editing the DNA at this early stage of development. [2 marks]

---

---

---

---

**(iii)** Suggest an advantage of the process taking place when undergoing in-vitro fertilisation rather than later during pregnancy. [1 mark]

---

---

**Blank Page**

**(Questions continue overleaf)**

**(b)** Blood cells are made in the bone marrow.

Leukaemia is a form of cancer caused by errors in the DNA of bone marrow cells.

One treatment method involves removing bone marrow from a patient and replacing it with healthy bone marrow cells (transplant) from a donor.

The donor needs to be a good tissue match with the patient to reduce the risk of the transplant being rejected.

However, for the transplant method to work, the treatment may need to be repeated several times.

Gene therapy can now be used to treat some forms of leukaemia.

This involves editing the DNA in the bone marrow cells of the person with leukaemia.

(i) Using the information provided and your knowledge, suggest three benefits of using gene editing rather than transplants from a donor to treat leukaemia. [3 marks]

1. \_\_\_\_\_

\_\_\_\_\_

2. \_\_\_\_\_

\_\_\_\_\_

3. \_\_\_\_\_

\_\_\_\_\_

The form of gene therapy described on page 44 involves repairing defective genes.

(ii) Apart from **repairing** defective genes, state **one** other method of gene therapy. [1 mark]

\_\_\_\_\_

\_\_\_\_\_

9 (a) Define the term **recessive allele**.

[1 mark]

---

---

---

(b) Batten disease is a rare, life-limiting, genetic human condition.

The allele for Batten disease is **not** sex-linked and is recessive.

Use the Punnett Square opposite to **show** how it is possible for two parents, neither of whom have Batten disease, to have a child who has the condition.

In your answer, use **B** for the dominant allele and **b** for the recessive allele.

Put a circle around the individual(s) with Batten disease. [4 marks]

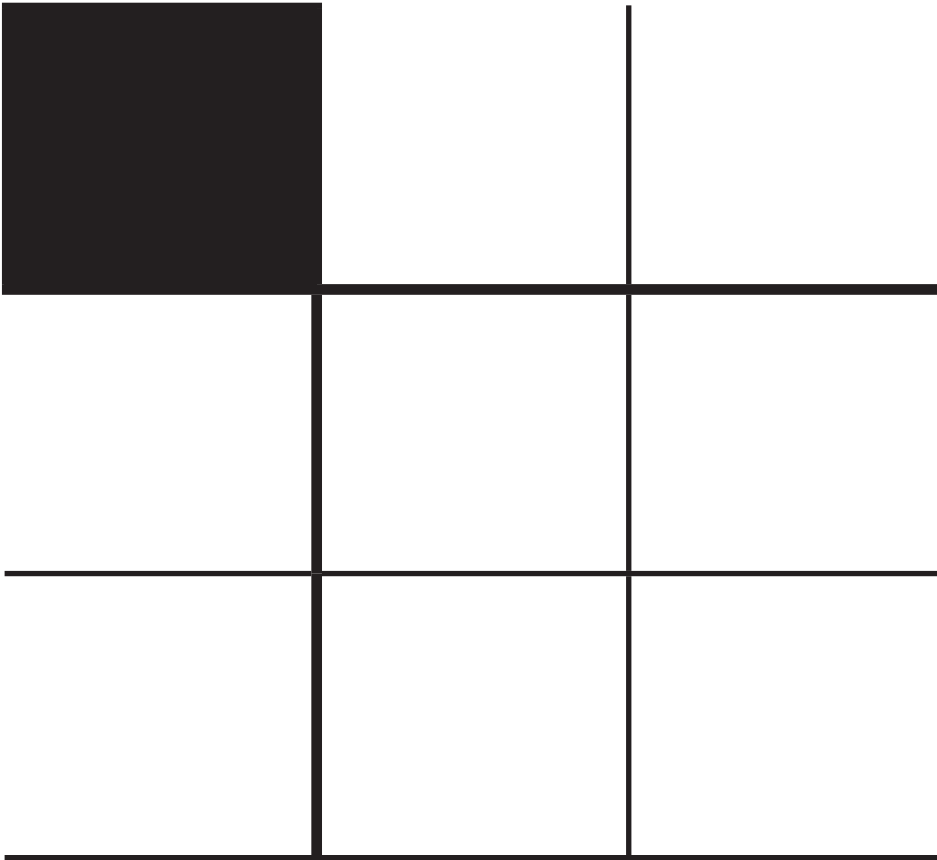

There are four blood groups in the human ABO system. Individuals can have blood groups A, B, AB or O.

There are three alleles ( $I^A$ ,  $I^B$  and  $I^O$ ) that determine the blood groups of individuals. The table below shows the four blood groups and their possible genotypes.

Blood group (phenotype)	Possible genotypes
A	$I^A I^A$ and $I^A I^O$
B	$I^B I^B$ and $I^B I^O$
AB	$I^A I^B$
O	$I^O I^O$

(c) Using the table, state the evidence which shows that the alleles  $I^A$  and  $I^B$  are co-dominant. [1 mark]

---

---

---

**(d) (i)** A person who does **not** have Batten disease and is blood group O can have two possible genotypes. One of these is **BB I<sup>O</sup>I<sup>O</sup>**. Give the other possible genotype. [1 mark]

---

A man with genotype **Bb I<sup>A</sup>I<sup>O</sup>** had children with a woman with the genotype **Bb I<sup>O</sup>I<sup>O</sup>**.

**(ii)** Give the four possible types of gametes the man with the genotype **Bb I<sup>A</sup>I<sup>O</sup>** could produce. [2 marks]

\_\_\_\_\_

\_\_\_\_\_

**(iii)** Give the two possible types of gametes the woman with the genotype **Bb I<sup>O</sup>I<sup>O</sup>** would produce. [1 mark]

\_\_\_\_\_ and \_\_\_\_\_

(iv) Complete the Punnett Square below to show the parental gametes and the genotypes of the offspring.  
[3 marks]

(v) Give the numbers of each of the phenotypes produced in this Punnett Square. [2 marks]

Does not have Batten disease and is blood group A \_\_\_\_\_

Does not have Batten disease and is blood group O \_\_\_\_\_

Has Batten disease and is blood group A \_\_\_\_\_

Has Batten disease and is blood group O \_\_\_\_\_

(vi) Give the probability of these parents having a child who has Batten disease and is also blood group O. [1 mark]

\_\_\_\_\_

(e) A species of beetle can have green or black wing cases and long or short wings.

The alleles for green wing cases and long wings are dominant.

In a cross between two beetles, each heterozygous for wing case colour and wing length, the following offspring numbers were obtained.

green wing cases and long wings: 93

green wing cases and short wings: 27

black wing cases and long wings: 33

black wing cases and short wings: 7

A chi-square test was carried out to check if the offspring numbers matched the expected 9:3:3:1 ratio.

A calculated  $\chi^2$  value of 1.6 was obtained.

The table below gives probability values for use in a  $\chi^2$  test.

		$\chi^2$ values					
		probability = 0.900	0.500	0.100	0.050	0.010	0.001
d.f.							
1	0.016	0.455	2.71	3.84	6.63	10.83	
2	0.211	1.39	4.61	5.99	9.21	13.82	
3	0.584	2.37	6.25	7.81	11.34	16.27	
4	1.06	3.36	7.78	9.49	13.28	18.47	
5	1.61	4.35	9.24	11.07	15.09	20.52	
6	2.20	5.35	10.64	12.59	16.81	22.46	
7	2.83	6.35	12.02	14.07	18.48	24.32	
8	3.49	7.34	13.36	15.51	20.09	26.13	
9	4.17	8.34	14.68	16.92	21.67	27.88	

(i) What is the number of degrees of freedom (d.f.) for the test? [1 mark]

---

(ii) Between which range of probabilities does the  $\chi^2$  fit? [1 mark]

\_\_\_\_\_ and \_\_\_\_\_

(iii) State the outcome of the statistical test. [1 mark]

\_\_\_\_\_  
\_\_\_\_\_  
\_\_\_\_\_

---

**This is the end of the  
question paper**

---



## SOURCES

Q5(c) . . . © Adapted from page 193, © *Biology for CCEA A2 Level, 2nd Edition (2017)*, Dr James Napier, publisher Colourpoint Educational, ISBN: 978-1780-731001

Q7(b) . . . © *Principal Examiner*

Q7(c) . . . © *Principal Examiner*

Q7(e) . . . © Adapted from Table 14b Rate down's Syndrome births, maternal age, Northern Ireland 2012-2016. NISRA. © Crown Copyright / NISRA. Contains public sector information licensed under the Open Government Licence v3.0

For Examiner's use only	
Question Number	Marks
1	
2	
3	
4	
5	
6	
7	
8	
9	

<b>Total Marks</b>	
--------------------	--

Examiner Number

Permission to reproduce all copyright material has been applied for. In some cases, efforts to contact copyright holders may have been unsuccessful and CCEA will be happy to rectify any omissions of acknowledgement in future if notified.